



Empore™ High Performance Extraction Disk Cartridges

October 1998

Instructions for Use

Product Description

3M™ Empore™ High Performance Extraction Disk Cartridges are used for the solid phase extraction (SPE) of analytes from liquid samples. This sample pretreatment procedure removes or minimizes sample matrix and other interferences to "clean-up" a sample prior to analysis. This procedure can also concentrate an analyte to achieve the desired sensitivity range of an analytical method. Compounds are isolated from complex mixtures by proper selection of a variety of sorbent chemistries.

The extraction product consists of a thin membrane, or disk, containing chromatographic sorbent particles that is mounted into the bottom of 1, 3 and 6 mL polypropylene syringe barrels. The effective membrane diameters are specified as 4, 7 and 10 mm, respectively. Placed securely on top of each membrane is a ring that seals the membrane into place. Above each ring is a prefilter that improves flow with challenging (particle-laden) sample matrices. All components of this high performance extraction device are made from polypropylene, except for the membrane which is composed of PTFE and sorbent particles.

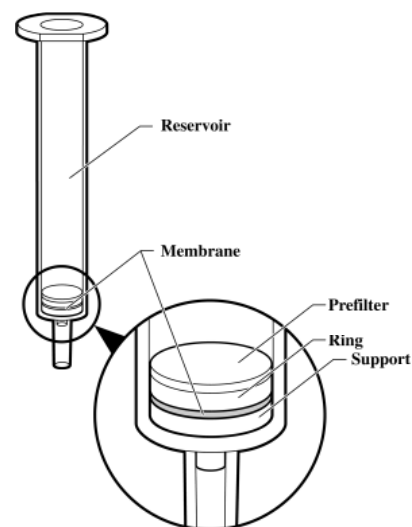

Patented Prefilter

The prefilter in Empore Extraction Disk Cartridges prevents particulates and micromolecules from reaching the underlying membrane and occluding its pores. It is composed of four types of randomly oriented polypropylene fibers that create a tortuous path of liquid flow. The pore size of the filter decreases with increasing depth, so that larger particles are trapped on the surface and throughout the interior of the filter. The prefilter has been experimentally determined to retain 98% of all particles larger than 10µm in size. Due to multiple layers and porosities within the filter, it also traps about 50% of particles as small as 2µm. Most analytes do not have an affinity for polypropylene and will pass through the filter

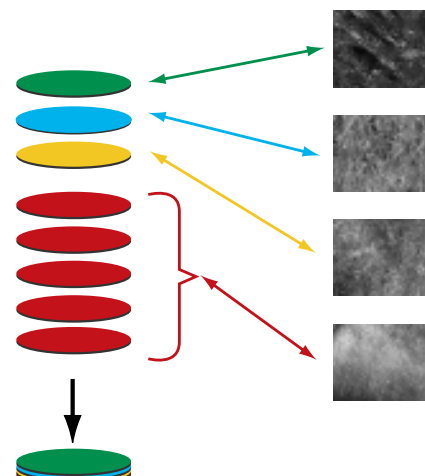

Particle-Loaded Membrane Technology

A patented 3M process transforms loose SPE sorbent particles into thin, particle-loaded membranes (disks). These disks consist of particles (e.g., bonded silica C2, C8, C18 and mixed phase cation, and various copolymers) tightly held together within an inert PTFE matrix (90% particles: 10% PTFE, w/w). The PTFE fibrils do not interfere with the activity of the particles. Empore disks are unique in achieving dense packing with uniform particle distribution. This particular disk technology minimizes loss of particles during analyte elution. The Empore membrane fabrication process can be further manipulated to create membranes of different densities (high density, 12 μ m particles, 0.5 mm thickness; standard density, 55 μ m particles, 0.75 mm thickness).

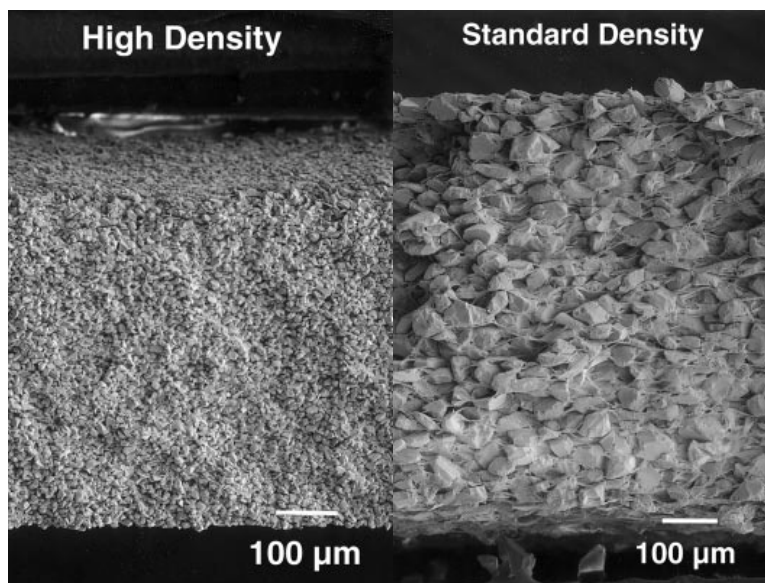

Micrograph of a cross section of a high density (HD) and a standard density (SD) Empore™ disk.

Advantages of Membrane Format

The Empore particle-loaded membrane represents a denser, more uniform extraction bed than can be achieved in a traditional SPE cartridge made from loosely packed particles. This technology results in an improvement in the efficiency and reproducibility of sample preparation techniques. The diffusion distance between particles is minimized, adsorption is more efficient, and extraction can be accomplished using less sorbent mass.

The distinct advantages of this membrane format over traditional loosely packed solid phase extraction material in columns are:

- Reduced solvent volumes
- Smaller elution volumes
- Reduced time for the evaporation step
- Ability to eliminate the evaporation step
- Higher throughput
- Minimal concerns with flow rate effects on recovery
- Significantly cleaner extracts with negligible fines

Product Specifications

Specifications (avg.) for Standard Density (SD) and High Density (HD) Empore Extraction Disk Cartridges

Effective Membrane Diameter	Reservoir Volume	SD Silica Mass*	HD Silica Mass	HD Copolymer Mass	SD Membrane Thickness	HD Membrane Thickness
4 mm	1 mL	5.5 mg	4 mg	2.2 mg	0.75 mm	0.5 mm
7 mm	3 mL	17 mg	12 mg	7.5 mg	0.75 mm	0.5 mm
10 mm	6 mL	35 mg	24 mg	15 mg	0.75 mm	0.5 mm

*Copolymer sorbent is not available in SD format

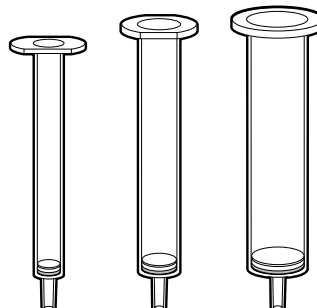

Product Selection

When developing a solid phase extraction method using Empore™ Extraction Disk Cartridges, a number of choices must be made. These choices refer to

1. Membrane Density
2. Cartridge Size
3. Sorbent Chemistry

Informed and proper choices lead to successful SPE methods. Note that each analytical compound is unique and only the analyst can be aware of the critical physicochemical factors influencing a specific analysis. The following general information is presented to familiarize you with the choices available in selecting Empore Extraction Disk Cartridges.

1. Membrane Density

Four bonded silica sorbents (C18, C8, C2, MPC) in Empore Extraction Disk Cartridges are available in both a standard density (SD) and a high density (HD) membrane format. Both SD and HD membrane formulations provide the same unique features of uniform particle distribution and dense packing, but vary with respect to particle size and membrane thickness.

The standard density format is designed for use with biological matrices and is recommended as the first choice for most applications. The high density format is reserved for situations when an even smaller elution volume is desired, and when the sample matrix is relatively clean (e.g., water or filtered serum).

2. Cartridge Size

SPE cartridges have traditionally been defined by sorbent mass and reservoir volume (e.g., 100mg/1mL). Empore™ Extraction Disk Cartridges are defined by disk diameter and reservoir volume. Three Empore™ Extraction Disk Cartridge sizes are available and are designated as 4mm/1mL, 7mm/3mL and 10mm/6mL. The selection of cartridge size for an application typically depends on three factors: (a) sample volume, (b) sample viscosity, and (c) elution volume requirements. A general guide to cartridge size selection is shown below.

Product Selection (Continued)

4mm/1mL Extraction Disk Cartridge

- Miniaturizes SPE
- Ideal for 0.05 to 0.5 mL sample volumes
- Fast throughput using automation
- Elution volumes are small and range from 100-200 μL *
- Small disk surface area results in slow flow characteristics if using vacuum
- Centrifugation recommended as processing method

7mm/3mL Extraction Disk Cartridge

- Most commonly used and versatile size
- Typically used for 0.5 to 2 mL sample volumes
- Fast throughput using automation
- Elution volumes range from 200-400 μL *
- Interchangeable with 100mg/1mL packed SPE columns

10mm/6mL Extraction Disk Cartridge

- Used for larger sample volumes of several milliliters
- Higher capacity
- Faster flow characteristics due to larger disk surface area
- Elution volumes range from 600-1000 μL *

**Elution volume will vary depending on the analyte, its affinity for the chosen sorbent, and the strength of the eluting solvent.*

3. Sorbent Chemistry

The ideal extraction closely matches the physicochemical properties of the analyte (pKa; acidic, neutral or basic characteristics; functional groups) with the sorbent chemistry and its solid support (silica or copolymer). In many cases, the sample matrix and the surrounding environment (pH and/or salt concentration) play an important role in matching analyte with sorbent.

Reversed Phase Extraction Using Bonded Silica (C18, C8, C2)

Reversed phase extraction is the most common type of SPE performed. In this case, an aliphatic hydrocarbon chain (C18, C8 or C2) is bonded to irregularly shaped silica particles. Analytes are retained by a combination of nonpolar interactions, Van der Waals forces, or secondary interactions (e.g., hydrogen bonding to silica silanols). C18 is strongly nonpolar and nonselective; so it tends to be used most often with success. C8 is moderately nonpolar and can be more selective than C18 for analytes. C2 is weakly nonpolar and has been demonstrated to retain less interferences than a strongly nonpolar C18.

Reversed Phase Extraction Using SDB-XC Copolymer

A frequently used alternative to a bonded silica sorbent for reversed phase extraction is based on a copolymer of poly(styrene-divinylbenzene), designated SDB-XC. This copolymer sorbent displays the following advantages over bonded silica sorbents:

- no secondary interactions
- no pH limitations
- greater capacity
- improved selectivity for moderately polar, water-soluble analytes

Product Selection (Continued)

Mixed Phase Extraction Using Bonded Silica (MPC)

Mixed phase cation (MPC) sorbent is a silica-based particle that has been bonded with both a reversed phase group (octyl) and a strong cation exchange group (benzene sulfonic acid). This mixed phase chemistry, in which two primary modes of attraction are present and pH is optimized for maximal analyte retention, allows for a more efficient and selective extraction of basic drugs compared with traditional reversed phase techniques. A unique feature of MPC is that acidic and neutral analytes can be extracted from a complex mixture and eluted separately from basic analytes.

Mixed Phase Extraction Using SDB-RPS Copolymer

Modification of SDB-XC by addition of sulfonic acid groups to the copolymer creates a different sorbent named SDB-RPS (Reversed Phase Sulfonated). The sulfonation imparts unique selectivity for organic analytes that are more polar, such as drug metabolites. New dimensions in selectivity and elution can be achieved by considering the influence of the sulfonic acid groups to provide some cation exchange affinity for amine-containing analytes. Although SDB-RPS is sulfonated, it has a much lower capacity than a typical strong cation exchanger.

Performing an Extraction Method

Five Basic Steps of Solid Phase Extraction

1. Condition the Disk
2. Load and Extract Sample
3. Wash out Interferences
4. Elute Analyte(s)
5. Prepare Eluate for Analysis

Condition the Disk

It is necessary to first wet a reversed phase sorbent by adding methanol (or acetonitrile). Pass most of the methanol through the disk but leave the surface of the disk wetted. Remove residual methanol by adding DI water (use a volume of water greater than that used for methanol). Pass most of the water through the disk but leave the surface of the disk wetted. Common processing methods (vacuum, positive displacement, centrifugation, automated liquid handling workstations) to pass liquids through the disk are explained in a separate section.

It is important that the disk not be allowed to dry prior to sample addition. If the disk does become dry, repeat the conditioning procedure.

Load and Extract Sample

Carefully transfer the sample into the extraction disk cartridge. Add internal standard (IS) and/or adjust sample pH as the method requires. Dilution of sample with an equal volume of buffer may improve flow, in addition to maintaining sample pH, and is suggested. Pass the sample/buffer solution through the disk.

Wash out Interferences

The goal of the wash step after sample loading is to remove co-extracted substances that could potentially interfere with the subsequent analysis. Water and buffers are commonly used as wash solvents for reversed phase extractions. They are effective at removing adsorbed proteins remaining on the surface of the sorbent bed. It is recommended to always use an aqueous wash initially after sample loading, rather than using only a single organic/aqueous mixture. Pass the entire volume of water through the disk.

Water or buffer alone may not provide sufficient clean-up in each assay. A second wash should contain a small percentage of organic solvent (commonly 5 to 20% organic in an aqueous mixture) to more efficiently remove

Performing an Extraction Method (Continued)

potential interfering substances. Note that the secondary wash should be chosen so that it removes as many interfering substances as possible without adversely affecting retention of the analyte(s) of interest. Pass the entire volume of wash solvent through the disk. Remove as much residual wash solvent as possible before the elution step is performed.

Elute Analyte(s)

Use a clean sample collection tube or vial for analyte elution. Note that the small bed volume of the disk allows for reduced elution volumes. Add to the extraction cartridge the proper volume of elution solvent necessary, depending on disk diameter, for analyte recovery (see Volume Guidelines section). Pass the elution solvent through the disk. Add a second aliquot, and repeat the elution. Briefly vortex mix the eluate solution before analysis so that it is homogeneous (the most concentrated portion of the eluate will be on the bottom of the tube or vial).

Prepare Eluate for Analysis

The ability to elute in small volumes from the disk may mean that the evaporation and reconstitution step may be eliminated. If the eluate is LC mobile phase or a compatible solvent, no additional steps are necessary (see Eliminating the Evaporation Step section). If organic solvent is used for elution, and further sample concentration is required to achieve the sensitivity limits of the assay, a typical procedure involves evaporation of the eluate under nitrogen (sometimes with heat applied). Reconstitution is then performed by adding a known volume of an appropriate solution (compatible with instrumental analysis) to the collection tube and vortex mixing before analysis.

Volume Guidelines

Reversed Phase Extractions

The small bed mass of sorbent in the disk cartridge allows for the use of smaller solvent volumes compared with traditional SPE products. A general guide to solvent volumes for a disk cartridge SPE method using reversed phase sorbents (C18, C8, C2, SDB-XC) is listed in the table below. Each assay will need some further optimization in terms of selecting the best wash solvent composition (10% methanol as shown in the example will not be optimal for all assays) and the particular elution solvent (commonly methanol or acetonitrile).

Important Notes: It is recommended to optimize the volume of elution solvent to ensure that the minimum volume is used that will elute the analyte reproducibly from the sorbent phase. Due to disruption of ionic interactions, which can be stronger than reversed phase interactions, slightly more elution solvent volume may be required for mixed phase disks than for a reversed phase sorbent.

**Volume Guidelines: Reversed Phase (C18, C8, C2, SDB-XC)
Empore Extraction Disk Cartridges (Standard Density)**

Step	Solvent	4mm/1mL	7mm/3mL	10mm/6mL
Condition	Methanol	150µL	250µL	500µL
	Water	300µL	500µL	1000µL
Load	Sample	250µL	1000µL	2000µL
	Buffer/IS	250µL	1000µL	2000µL
Wash	Water	300µL	500µL	1000µL
	Organic/Aqueous	300µL	500µL	1000µL
Elute	Organic	100-150µL	200-300µL	600-800µL

Volume Guidelines (Continued)

Notes: Elution volumes are provided as a range and should be optimized for each analyte; volumes required for high density disk cartridges would be slightly smaller

Mixed Phase Extractions

A general guide to solvent volumes for a disk SPE method using a mixed phase sorbent (both reversed phase and cation exchange bonded to same support) is listed in the table below. The conditioning and wash solvent sequences are common and usually do not vary between assays. The most common elution solvent used is (dichloromethane/-isopropanol/ammonium hydroxide (78:20:2, v/v/v), prepared fresh daily. Alternate elution solvents include methanol/ammonium hydroxide or acetonitrile/ammonium hydroxide (98/2, v/v).

Volume Guidelines: Mixed Phase (MPC, SDB-RPS) Empore Extraction Disk Cartridges				
Step	Solvent	4mm/1mL	7mm/3mL	10mm/6mL
Condition	Methanol	150µL	250µL	500µL
	Water	300µL	500µL	1000µL
Load	Sample	250µL	1000µL	2000µL
	Buffer/IS	250µL	1000µL	2000µL
Wash	Water	300µL	500µL	1000µL
	Organic/Aqueous	300µL	500µL	1000µL
Elute	CH ₂ Cl ₂ /IPA/- NH ₄ OH (78/20/2)	150-200µL	300-400µL	800-1000µL

Notes: Elution volumes are provided as a range and should be optimized for each analyte; volumes required for high density disk cartridges would be slightly smaller

Sample Processing Options

The dense particle packing of the disk prevents sample from flowing freely under gravity. Some type of vacuum or positive displacement is always required to force liquids through the disk. The following methods have proved successful in processing liquids through the membrane:

1. Vacuum
2. Positive Displacement
3. Centrifugation
4. Automated Liquid Handling Workstations

Vacuum

A vacuum manifold is commonly used to pass liquids through the disk. These manifolds are available from many vendors and generally hold from 12 to 24 cartridges at a time. Test tubes are placed below each cartridge position to collect liquids during each step. Note that these manifolds are not designed to effectively use the low volumes made possible by Empore™ Extraction Disk Cartridges (but were designed for packed column SPE cartridges that require much larger solvent volumes for processing).

Vacuum Recommendations

Empore™ Extraction Disk Cartridges (standard density, SD) generally require from 10-15 in Hg (0.34 to 0.51 bar) to process biological fluids such as plasma and serum when using vacuum. High density disk cartridges require maximum vacuum, about 20 in Hg (0.68 bar). Note that if the sample matrix is relatively clean and of a small volume, a lower vacuum may be used.

Sample Processing Options (Continued)

A general guide is to open the vacuum source to about 15 in Hg (0.51 bar) for all steps, with two exceptions:

1. During method optimization, try loading the sample matrix at both a low vacuum (5-7 in Hg; 0.17 to 0.24 bar) and a high vacuum (about 17-20 in Hg; 0.58 to 0.68 bar). If an analyte has a low affinity for the sorbent, it may need to pass through the sorbent bed more slowly during the load step for sufficient attraction to occur.
2. A lower vacuum is generally desirable during the elution step to prevent splashing in the collection device. A lower vacuum may also be beneficial when eluting from MPC sorbent, as a slower flow rate will allow more time to disrupt ionic interactions (which are stronger than reversed phase interactions).

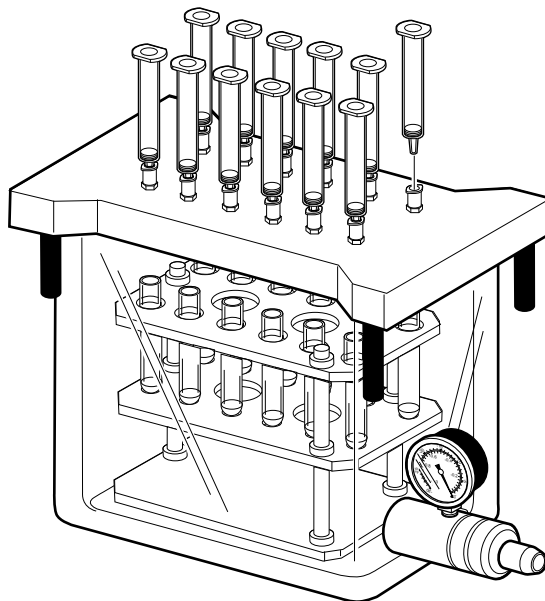

Positive Displacement

Positive air displacement can be used in a manual mode with disk cartridges. In this manner, one sample at a time can be processed by attaching a syringe to an adaptor that fits between the cartridge and the syringe. Air is forced through the cartridge and displaces liquids.

A single piece device, the Visi-1 (Supelco catalog #57080), is a similar approach that eliminates the need for a separate adaptor. It also provides for a more finely controlled positive displacement, resulting in tighter flow control.

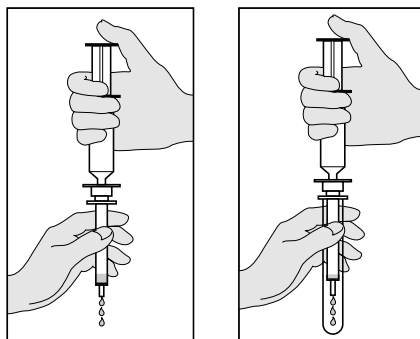

Note that a specific type of manifold delivers positive pressure instead of using vacuum for processing liquids. Multiple cartridges can be processed at a time. It is available from Varian Sample Preparation Products.



Sample Processing Options (Continued)

Centrifugation

Positive pressure via centrifugation is another option for processing liquids through disk cartridges. Centrifugation can be preferable to vacuum as it requires less manipulation and permits more complete volume collection. Often, centrifugal forces of 75-120g are used; or from 1200-2750 RPM in

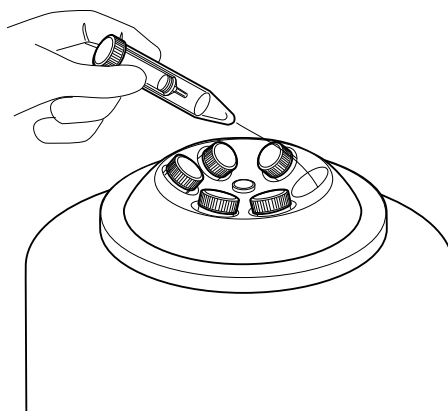

general terms. Forces greater than these numbers may be used, but first examine the effect on analyte recovery. With centrifugation, the disk cartridge is suspended in a test tube and placed into a carrier tray that fits into the centrifuge.

Conditioning can be done off-line manually (see Positive Displacement section) or as part of the centrifugation method.

Automated Liquid Handling Workstations

Several different liquid handling workstations are commercially available to automate the extraction process. They use either positive displacement or vacuum to move liquids through the disk, utilizing unique methods (e.g., plunger, cap insertion, sealing plate). These systems, in combination with the disk format, can be an ideal combination to offer improved throughput. The possibility for human pipetting error and/or procedural error is eliminated.

Eliminating the Evaporation Process

The design of the Empore disk format allows for the use of reduced elution volumes. The need for a time-consuming evaporation and reconstitution step can often be eliminated. Two approaches for eliminating the evaporation step are commonly employed:

1. **Two-Step Elution:** Elute with a small volume of organic solvent, then add a volume of aqueous liquid so that the composition of the resulting solution is compatible with mobile phase.
2. **Mobile Phase Compatible Elution:** Elute using a solvent with sufficient organic content to desorb analyte but which is also compatible with mobile phase for direct injection.

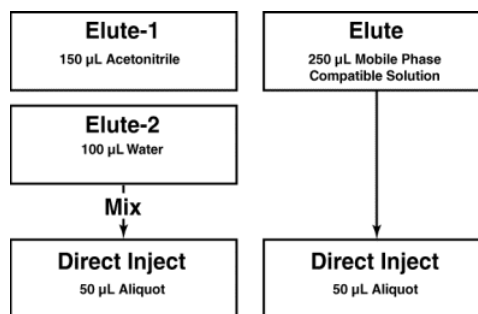

The volumes shown above are only examples. Elution volume will vary depending on the disk cartridge size, the physical/chemical characteristics of the analyte, affinity of the analyte for the chosen sorbent, and the strength of the eluting solvent.

Method Examples

Listed below are general methods for both a reversed phase extraction (C18, C8, C2, SDB-XC) and a mixed phase extraction (MPC, SDB-RPS). Suggested volumes can be found in **Volume Guidelines** section.

Reversed Phase Extraction

Condition	Methanol DI Water
Load	Sample Buffer and internal standard (IS) (<i>apply in 1:1 sample:buffer ratio</i>)
Wash	Water Methanol/Water or Acetonitrile/Water (e.g., 10/90, v/v)
Elute	Methanol (or Acetonitrile)

Mixed Phase Extraction

Condition	Methanol DI Water Phosphate Buffer 0.1M, pH 6.0
Load	Sample* Phosphate Buffer/IS 0.1M, pH 6.0 (<i>apply in 1:2 sample:buffer ratio</i>)
Wash	Water Acetic acid 1.0M Methanol
Elute	Dichloromethane/isopropanol/ammonium hydroxide (78:20:2, v/v/v)** (<i>Prepare fresh reagent solution daily</i>)

*Sample pH should be at least two units below the pKa. Use ionic strength buffer of 0.1M or less.

**Alternate elution solvents:

hexane/ethyl acetate (50/50, v/v)

ethyl acetate/ammonium hydroxide (98/2, v/v)

methanol/ammonium hydroxide (98/2, v/v)

acetonitrile/ammonium hydroxide (98/2, v/v)

Visit Our Web Site

Detailed product and technical information, including *Instructions for Use* and *Answers to Frequently Asked Questions*, can be found on the Internet.

www.mmm.com/empore

IMPORTANT NOTICE TO PURCHASER

All statements, technical information and recommendations contained in this literature are based on tests conducted with 3M approved equipment and are believed to be reliable. However, the accuracy or completeness of the tests are not guaranteed. THE FOLLOWING IS MADE IN LIEU OF ALL WARRANTIES, EXPRESS OR IMPLIED, INCLUDING THE IMPLIED WARRANTIES OF MERCHANTABILITY AND FITNESS FOR A PARTICULAR PURPOSE: The seller's and manufacturer's only obligation will be to replace the quantity of the product proved to be defective. Neither the seller nor 3M will be liable for any injury, loss or damage, direct or consequential, arising out of the use of or the inability to use the product. Before using, the user must determine the suitability of the product for his or her intended use. This product is intended for scientific research use only.



3M Bioanalytical Technologies

3M Center, Building 270-2A-08
St. Paul, MN 55144-1000
Tel. 1 888 509 5330
Fax 1 651 736 4882

Litho in the USA

©3M 1998 78-6900-7440-2