

# Solvex™ Solvent Filtration Cartridge Filters

Reliable Filtration Designed to Fit Your Needs



Optimized filtration means meeting the changing requirements of your processes and the regulations that govern them. This is why we offer you a choice. Solvex™ hydrophobic 0.2 µm solvent filtration products provide validated, robust, and cost-efficient solvent filtration. Our Solvex™ brand cartridge filters combine high-performance polytetrafluoroethylene (PTFE) membranes with a robust cartridge design to deliver validated, reliable sterile filtration and efficient particulate removal. A polymer with broad chemical and caustic compatibility, PTFE is ideal for use in the manufacture of active pharmaceutical ingredients containing methylene chloride, acetone, isopropyl alcohol, ethyl acetate and other organic solvents.

## Benefits

- Ideal for sterile manufacture of active pharmaceutical ingredients (API)
- Suitable for filtration of a wide variety of organic solvents
- Robust construction and easy scale-up to meet changing process needs

Solvex™ filters meet your highest standard for sterility assurance, regulatory compliance and economy. With the quality you expect from a trusted supplier, Solvex™ brand solvent filters offer superior value through consistent and reliable performance that is guaranteed for up to 100 steam-in-place cycles. Solvex™ PTFE cartridge filters are available in 10, 20, and 30 inch sizes in code 7 O-ring adapters. Validation services and applications support are available through our BioReliance® Validation Services program.

### Reliability

Solvex™ cartridge filters promote a consistent, repeatable manufacturing process characterized by high-capacity, low extractables, and resistance to thermal and hydraulic stress. The proven performance of our filtration devices ensures uniform results every time.

### Compliance

Our cartridges are designed and thoroughly validated for product and process quality. Each lot of Solvex™ filters is verified during manufacture for flow rate and bacterial endotoxins and each cartridge is tested for integrity prior to release.

### Economy

Solvex™ cartridge filters gives you the flexibility of reusing the filter multiple times, promoting an economical filtration process. Solvex™ cartridges can be steamed in place up to 100 times at temperatures of up to 135 °C.

**Figure 1.** Solvex™ Cartridge Water Flow Rate vs. Differential Pressure at 23 °C\*

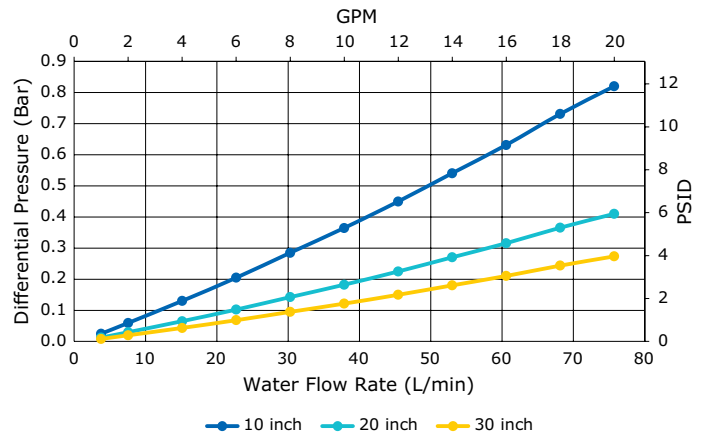

\* Typical Values for H<sub>2</sub>O.

**Figure 2.** Hydrophobic 0.2 µm Cartridge Filters in Antibiotic Production

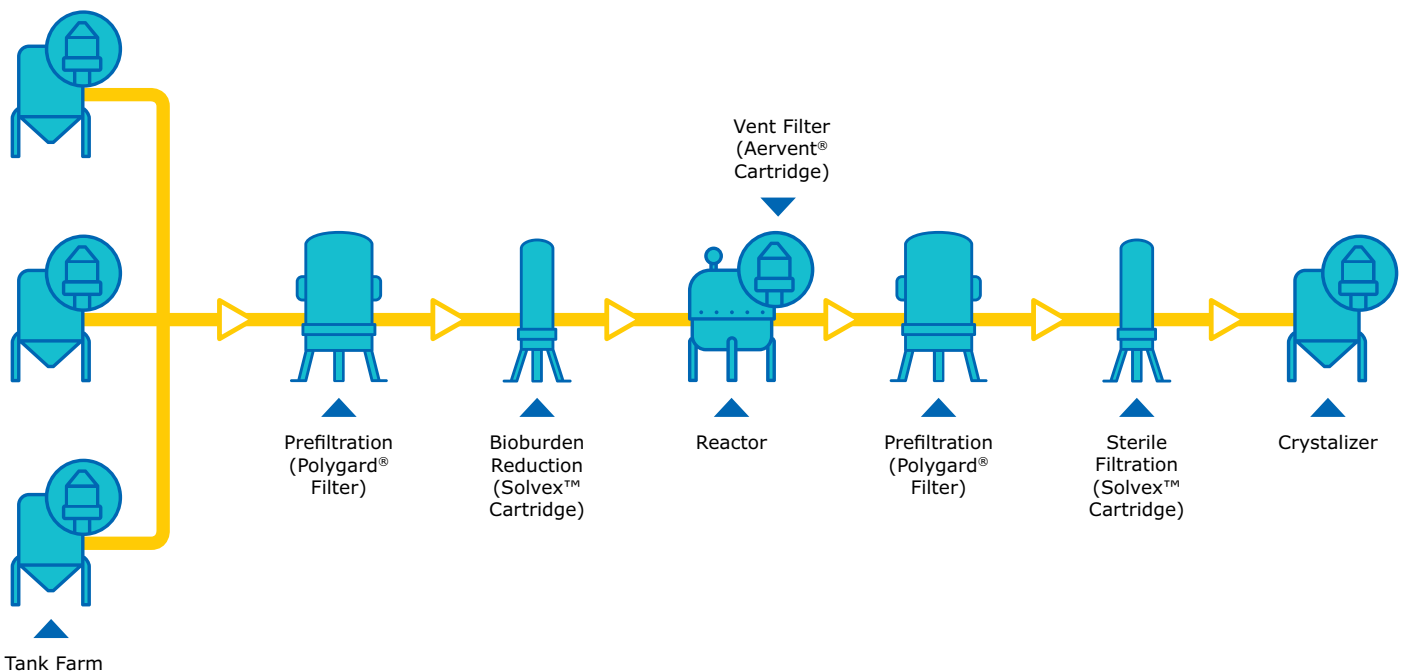

## Specifications

<b>Nominal Dimensions</b>	
Outside diameter:	70 mm (2.8 in.)
Maximum length:	
10-inch cartridge	319 mm (12.6 in.)
20-inch cartridge	568 mm (22.0 in.)
30-inch cartridge	816 mm (32.1 in.)
<b>Filtration Area</b>	0.65 m <sup>2</sup> (7.0 ft <sup>2</sup> )
<b>Materials of Construction</b>	
Filter media:	PTFE membrane
Supports:	Polypropylene
Structural components:	Polypropylene
O-rings:	EPDM
<b>Maximum Differential Pressure</b>	
Forward:	5.5 bar (80 psid) at ambient temperature, 1.8 bar (25 psid) at 80 °C
Reverse:	4.1 bar (60 psid) at ambient temperature
<b>Diffusion at 23 °C</b>	Through a 70/30 IPA/water wet membrane at 965 mbar (14 psig) nitrogen: ≤24 cc/min per 10-inch cartridge
<b>Bubble Point at 23 °C</b>	≥1310 mbar (19 psig) in a 70/30 IPA/water wet membrane using nitrogen
<b>Gravimetric Extractables</b>	After autoclaving and a 24 hour soak in 70/30 IPA water at controlled room temperature: ≤ 35 mg per 10-inch cartridge
<b>Bacterial Endotoxin</b>	Aqueous extraction contains < 0.25 EU/mL as determined by the Limulus Amebocyte Lysate (LAL) Test.
<b>Bacterial Retention</b>	Samples were quantitatively retentive of a minimum <i>Brevundimonas diminuta</i> challenge concentration of 1 x 10 <sup>7</sup> CFU/cm <sup>2</sup> using ASTM® F838 methodology.
<b>Sterilization</b>	May be steam sterilized 50 times (forward) and 50 times (reverse) for 30 minutes at 135 °C
<b>Good Manufacturing Practices</b>	These products are manufactured in a facility which adheres to Good Manufacturing Practices.
<b>Non-Fiber Releasing</b>	PTFE membrane meets the criteria for a “non-fiber releasing” filter as defined in 21 CFR 210.3 (b) (6).
<b>Component Material Toxicity</b>	Component materials meet the criteria of the USP <88> Reactivity Test for Class VI Plastics. This product is non-cytotoxic per ISO® 10993-5 and USP <87> Cytotoxicity MEM Elution Test.

## Ordering Information

### Solvex™ PTFE 0.2 µm Filter Cartridge for Solvent Filtration

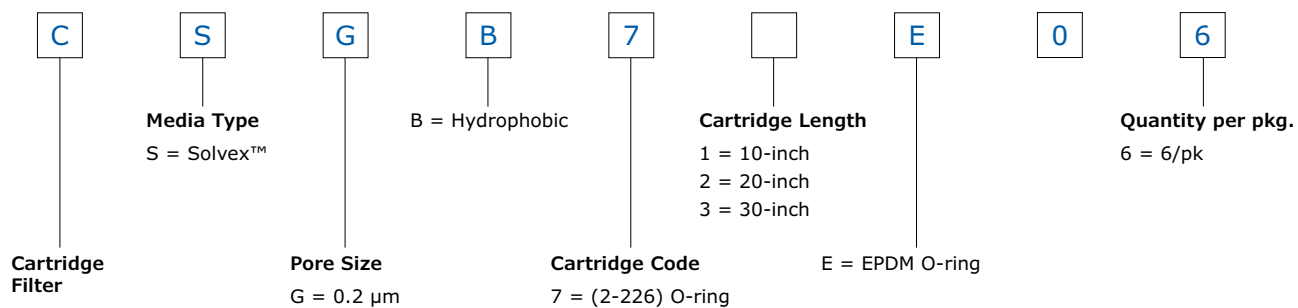

### To place an order or receive technical assistance

In the U.S. and Canada, call toll-free 1-800-645-5476

For other countries across Europe and the world, please visit: [EMDMillipore.com/offices](https://www.emdmillipore.com/offices)

For Technical Service, please visit: [EMDMillipore.com/techservice](https://www.emdmillipore.com/techservice)

[EMDMillipore.com](https://www.emdmillipore.com)

MilliporeSigma  
400 Summit Drive  
Burlington, MA 01803

